

## Main Feature

1. The design of twin make contacts (DPST) with the switching capacity of 16 Amps.
2. Two types of power consumption 0.8W (D type) and 0.48W (L type) available for customer's selection.
3. Suitable plastic material is used for various chemical solution and high temperature.
4. Hand soldered type and the internal construction are designed to protect Relay from dust.
5. With 8.5 mm flat cable plug available.

## Application

Home appliances, Industrial machine and Control Equipment etc.

## Contact Rating

- Nominal Load (Resistive Load  $\cos \phi = 1$ )  
Contact Capacity ..... 16A at 250VAC.  
12A at 400VAC.  
Rated Carrying Current ..... 16A.  
Max. Allowable Current ..... 25A.  
Max. Allowable Voltage ..... AC 400V.  
Max. Allowable Power Force 4800VA.  
Min. Switching Load ..... DC 10V, 10mA.
- Contact Material ..... Ag Alloy.
- Contact Form ..... DPST.

## Performance (at Initial Value)

- Contact Resistance ..... 100m $\Omega$  Max. @1A, 6VDC
- Operate Time ..... 10 mSec. Max.
- Release Time ..... 6 mSec. Max.
- Dielectric Strength :  
Between Coil & Contact ..... 4,000VAC at 50/60 Hz  
for one minute.  
Between Contacts ..... 2,500VAC at 50/60 Hz  
for one minute.
- Surge Resistance ..... 10,000V (between Coil & Contact 1.2x50 $\mu$ Sec.)
- .... Insulation Resistance ..... 100 Mega $\Omega$  Min. at 500VDC.

- Max. On/Off Switching :  
Electrical ..... 900 Ops per Hour.  
Mechanical ..... 900 Ops per Hour.
- Temperature Range ..... -40~90°C
- Humidity Range ..... 45~85% RH.
- Coil Temperature Rise ..... 60°C Max.
- Vibration :  
Endurance ..... 10 to 55 Hz dual  
amplitude width 1.5mm.  
Error Operation ..... 10 to 55 Hz dual  
amplitude width 1.5mm.
- Shock :  
Endurance ..... 1,000 m/S<sup>2</sup> Min.  
Error Operation ..... 100 m/S<sup>2</sup> Min.
- Life Expectancy :  
Mechanical ..... 2 x 10<sup>6</sup> Operations at No  
Load condition.  
Electrical ..... 10<sup>5</sup> Operations at Rated  
Resistive Load.
- Weight ..... About 38.0 g.

## Safety Standard & Its File Number

- NIL

### Coil Specification (at 20°C)

Coil Sensitivity	Nominal Voltage (VDC)	Nominal Current (mA)	Coil Resistance ( $\Omega \pm 10\%$ )	Power Consumption (W)	Pull-In Voltage (VDC)	Drop-Out Voltage (VDC)	Maximum Allowable Voltage (VDC)
EW-DM	9	88.8	101	Abt. 0.80	80% Maximum	5% Minimum	150%
	12	66.6	180				
	24	33.3	720				
EW-LM	9	53.3	168	Abt. 0.48	80% Maximum	5% Minimum	150%
	12	40	300				
	24	20	1,200				

### Ordering Information

EW - S - 2 12 D M

**Contact Form:** M: One Form A

**Coil Type:** D: Standard DC Coil

**Coil Voltage:** L: High Sensitivity DC Coil

**Number of Pole:** 09: 9V, 12: 12V, 24: 24V

**Type of Sealing:** 2: Two Poles

**S:** Hand Soldered Type

**EW**

### Classification

Model	EW	
Coil Sensitivity	Standard DC Coil	High Sensitivity DC Coil
Hand Soldered Type	EW-S-2□□DM	EW-S-2□□LM

### Dimension

EW-DM/LM

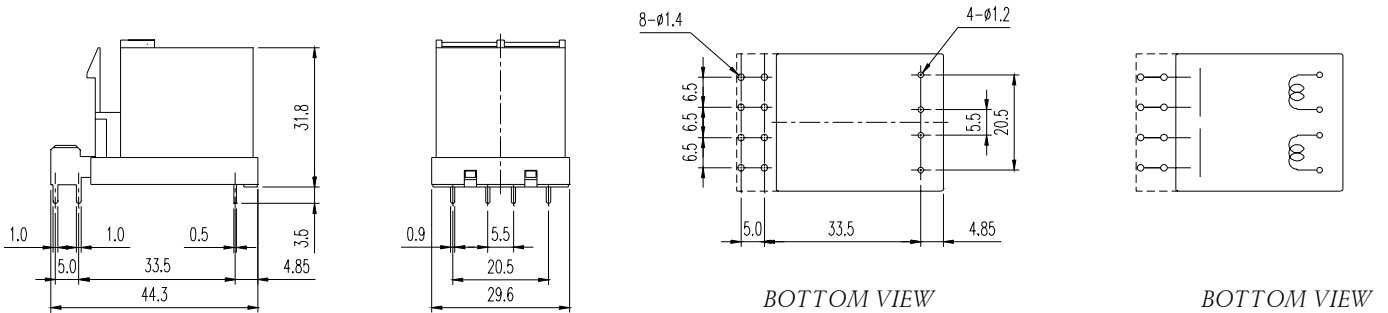

### Reference Data

Electrical Life to Current

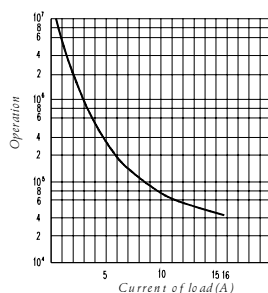

Reduction for Inductive Load

